

DISCLAIMER. This collection of practice problems is *not* guaranteed to be identical, in length or content, to the actual exam. You may expect to see problems on the test that are not exactly like problems you have seen before.

Please note! The following represents the answers as I have computed them, *not* complete solutions. There may be typos or other errors. If your answers do not agree with the ones listed here, or you do not know how to do a problem, please feel free to e-mail me or see me in office hours. Good luck!

Multiple Choice. Circle the letter of the best answer.

1. The area between the curves $f(x) = 3x - 1$ and $g(x) = x^2 + 1$ from $x = 2$ to $x = 5$ is

(a) $\int_2^5 (3x - 1) - (x^2 + 1) dx$ (c) $\int_2^3 (3x - 1) - (x^2 + 1) dx + \int_3^5 (x^2 + 1) - (3x - 1) dx$
(b) $\int_2^5 (x^2 + 1) - (3x - 1) dx$ (d) $\int_2^4 (x^2 + 1) - (3x - 1) dx + \int_4^5 (3x - 1) - (x^2 + 1) dx$

2. The weight of a leaky bucket when carried x feet up a 20-foot ladder is $30 - 2x$ pounds. The work done in carrying the bucket from the ground to the top of the ladder is

(a) 200 ft.-lb. (c) 300 ft.-lb.
(b) 250 ft.-lb. (d) 350 ft.-lb.

3. The average value of the function $f(x) = \sqrt[3]{x}$ from $x = 1$ to $x = 8$ is

(a) $\frac{45}{4}$ (c) $\frac{45}{28}$
(b) $\frac{45}{7}$ (d) $\frac{45}{14}$

4. $\int_0^1 xe^{3x} dx =$

(a) $\frac{1}{6}e^3$ (c) $\frac{1}{3}(e^3 - 1)$
(b) $\frac{2}{3}(e^3 + 1)$ (d) $\frac{1}{9}(2e^3 + 1)$

5. $\int \sin^3 x \cos x dx =$

(a) $\frac{1}{4} \cos^4 x + C$ (c) $-\frac{1}{4} \sin^4 x + C$
(b) $\frac{1}{4} \sin^4 x + C$ (d) $-\frac{1}{4} \cos^4 x + C$

6. Using trigonometric substitution, the integral $\int \frac{x^3}{\sqrt{1-x^2}} dx$ is equal to

(a) $\int \sin^3 \theta d\theta$

(c) $\int \frac{\sin^3 \theta}{\cos^2 \theta} d\theta$

(b) $\int \frac{\sin^3 \theta}{\cos \theta} d\theta$

(d) $\int \sin^2 \theta \cos \theta d\theta$

7. $\int \frac{3}{2+x^2} dx =$

(a) $\frac{3}{2} \tan^{-1}(x) + C$

(c) $\frac{3\sqrt{2}}{2} \tan^{-1}\left(\frac{x}{\sqrt{2}}\right) + C$

(b) $-\frac{3}{2+x} + C$

(d) $-\frac{3}{4}x^2 + C$

8. $\int_2^\infty \frac{1}{x^4} dx =$

(a) $\frac{1}{6}$

(c) $\frac{3}{20}$

(b) $\frac{1}{24}$

(d) ∞ (diverges)

9. The length of the curve $f(x) = 5x^2$ from $x = 1$ to $x = 4$ is

(a) $\int_1^4 \sqrt{1+100x^2} dx$

(c) $\int_1^4 \sqrt{1+5x^2} dx$

(b) $\int_1^4 1+5x^2 dx$

(d) $\int_1^4 \sqrt{10x} dx$

10. The area of the surface formed by rotating the curve $f(x) = 5x^2$ from $x = 1$ to $x = 4$ about the y -axis is

(a) $\int_1^4 \sqrt{1+100x^2} dx$

(c) $2\pi \int_1^4 \sqrt{1+5x^2} dx$

(b) $2\pi \int_1^4 x\sqrt{1+100x^2} dx$

(d) $\int_1^4 5x^2\sqrt{10x} dx$

11. After eliminating the parameter, the curve $\begin{matrix} x = e^t - t \\ y = t^3 \end{matrix}$ is identical to the curve

(a) $x = e^{\sqrt[3]{y}} - \sqrt[3]{y}$

(c) $y = (e^x - x)^3$

(b) $x = e^{y^3} - y^3$

(d) $y = e^{x^3} - x^3$

12. The Cartesian coordinates for the polar point $(-\frac{1}{2}, \frac{3\pi}{2})$ are

(a) $(\frac{1}{2}, 0)$

(c) $(-\frac{1}{2}, 0)$

(b) $(0, \frac{1}{2})$

(d) $(0, -\frac{1}{2})$

13. The sequence $a_n = \frac{2n}{3n-1}$

(a) converges to 0

(c) converges to $\frac{2}{3}$

(b) converges to 1

(d) diverges

14. The series $\sum_{n=1}^{\infty} \frac{2n}{3n-1}$

(a) converges to 0

(c) converges to $\frac{2}{3}$

(b) converges to 1

(d) diverges

15. In order to determine whether or not the series $\sum_{n=1}^{\infty} \frac{(-1)^n 5n}{3n^2-1}$ converges, the limit comparison test may be used with comparison series $\sum b_n =$

(a) $\sum \frac{5}{3n^2}$

(c) $\sum \frac{1}{n^2}$

(b) $\sum \frac{(-1)^n}{n}$

(d) none; the limit comparison test cannot be used

16. The series $\sum_{n=0}^{\infty} \frac{(-1)^n (x-2)^n}{5^n}$

(a) converges for $\frac{9}{5} < x < \frac{11}{5}$ only

(c) converges for all x

(b) converges for $-3 < x < 7$ only

(d) converges only for $x = 2$

17. The series $\sum_{n=0}^{\infty} \frac{(-1)^n 3^{2n}}{(2n)!}$

(a) converges to $\sin 3$

(c) converges to 3

(b) converges to $\cos 3$

(d) diverges

18. The binomial series of the function $f(x) = \frac{1}{(1-x)^5}$ is

(a) $\sum_{n=0}^{\infty} \binom{-5}{n} (-1)^n x^n$

(c) $\sum_{n=0}^{\infty} \binom{5}{n} (-x)^n$

(b) $\sum_{n=0}^{\infty} \binom{-5}{n} x^n$

(d) $\sum_{n=0}^{\infty} \binom{n}{-5} (-1)^n x^n$

Fill-In.

1. Circle the best answer.

In order to find the volume of the solid formed by rotating the region enclosed by $y = x^2 + 1$ and $y = 3x - 1$ about the x -axis, it is best to use the (**disk** | **shell**) method.

2. Fill in the correct numerators. Your answers should be numbers or polynomials, not $A, B, etc.$

$$\frac{4x - 1}{(x - 2)(x + 3)^2} = \frac{\boxed{\frac{7}{25}}}{x - 2} + \frac{\boxed{-\frac{7}{25}}}{x + 3} + \frac{\boxed{\frac{13}{5}}}{(x + 3)^2}$$

3. Circle the best answer.

The series $\sum_{n=1}^{\infty} \frac{3n^2 - 1}{n^5}$ (**converges absolutely** | **converges conditionally** | **diverges**)

4. $\binom{3/2}{4} = \frac{3}{\underline{64}}$.

Graphs. More accuracy = more points!

1. On the axes at right, sketch the solid formed by rotating the region shown about the y -axis.

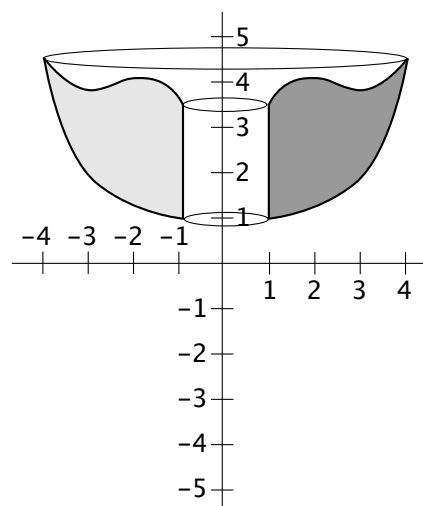

- (a) For the function $f(x)$ graphed at right, sketch a **rectangle** on the same axes whose area is approximately $\int_1^5 f(x) dx$.
2. (b) The average value f_{ave} of $f(x)$ from $x = 1$ to $x = 5$ is approximately 11.5.
- (c) The approximate value(s) of c so that $f(c) = f_{\text{ave}}$ is/are 1, 2.3 (list all values).

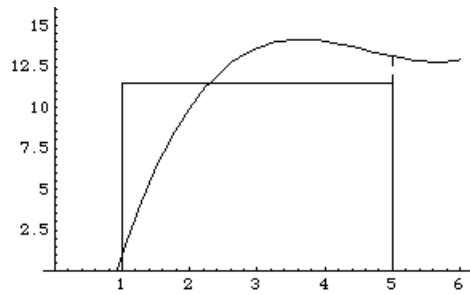

Work and Answer. You must show all relevant work to receive full credit.

- Find the area of the region enclosed by the curves $y = 4 - x^2$ and $y = x + 2$.
 $\frac{9}{2}$
- If the force required to pump water at depth x over the side of a tank 2 meters deep is $F(x) = 9800(3x^2 + 4x)$ Newtons, find the work done to pump all the water out.
 156,800 J
- Evaluate $\int \ln x dx$.
 By parts: $x \ln x - x + C$
- Evaluate $\int \tan^{-1} x dx$.
 By parts: $x \tan^{-1} x - \frac{1}{2} \ln(1 + x^2) + C$
- Evaluate $\int_0^{\infty} x e^{-x^2} dx$.
 $\frac{1}{2}$
- Find the sum $\sum_{n=0}^{\infty} \frac{3}{4^n}$.
 4
- Determine whether the series $\sum_{n=0}^{\infty} \frac{(-1)^n (n^2 + 1)}{5^n}$ is absolutely convergent, conditionally convergent, or divergent.
 AC

8. Find the interval of convergence of the power series $\sum_{n=1}^{\infty} \sqrt{n}x^n$.

$$-1 \leq x < 1$$

9. Find a power series representation for the function $f(x) = \ln(1+x)$.

$$\sum_{n=0}^{\infty} \frac{(-1)^n}{n+1} x^{n+1}$$

10. Find a power series representation for the function $f(x) = \sin(2x)$.

$$\sum_{n=0}^{\infty} \frac{(-1)^n}{(2n+1)!} (2x)^{2n+1}$$

11. (a) Find a power series representation for the function $f(x) = (2+3x)^{10}$.

(b) Find the coefficient of x^3 in the above series.

(a) $\sum_{n=0}^{\infty} \binom{10}{n} \frac{3^n}{2^{n-10}} x^n$

(b) 414,720

Some kind of **BONUS**.